

 ECO Inline Meter (base, measuring capsule and dual check valve) **must be installed by a licensed plumber** in accordance with **AS/NZS 3500** and **local government requirements**.

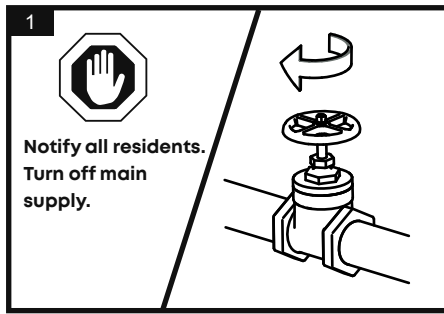

NEW INSTALLATION

CAPSULE REPLACEMENT

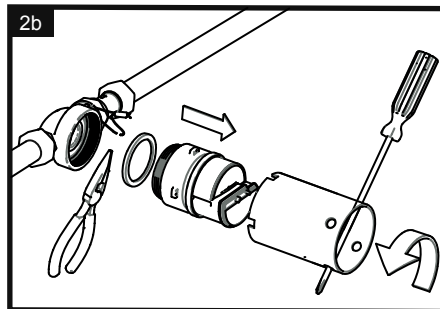
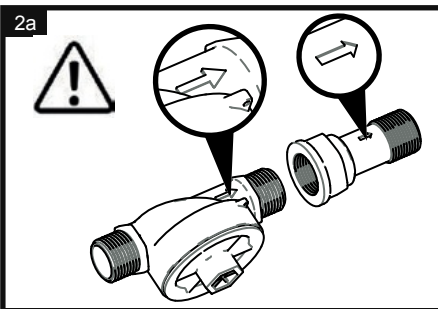

Apply thread seal to **male threads only**.
Fit mini dual check valve to outlet.
 **Flow direction must correspond.**
Fit assembly onto the supply line.

Remove old measuring capsule.

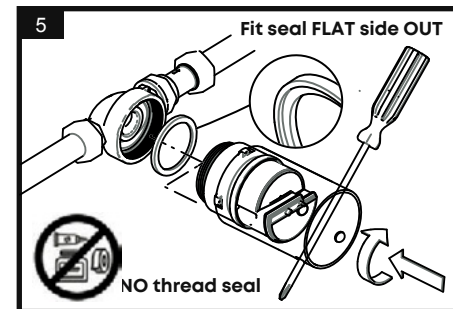
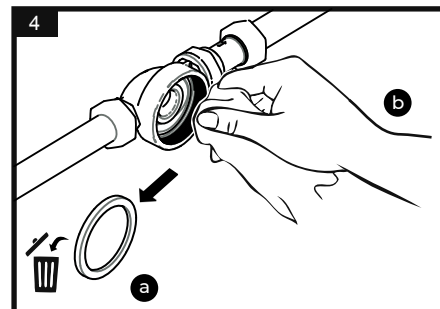
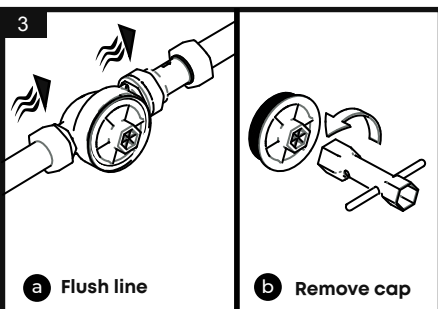

a) Flush the line to remove any debris.
b) Remove protective cap.

a) Remove and discard seal.
b) Clean the seal area.

Fit new seal - stepped side in, flat side out.
 **DO NOT use thread seal of any kind** as this will void warranty.
Install new measuring capsule.

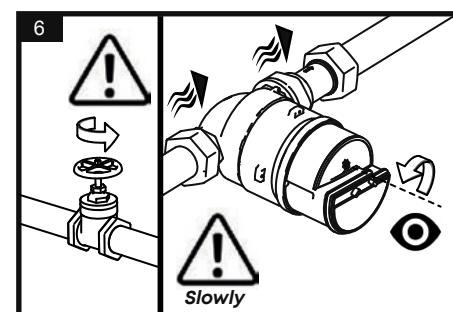
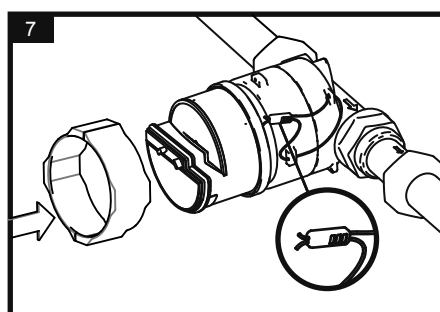
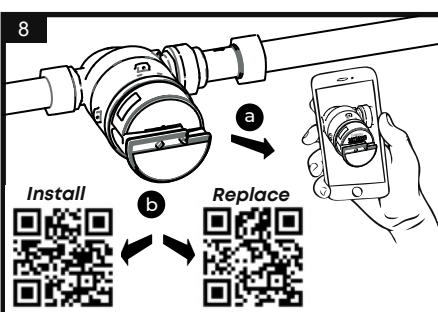

a) Photograph both serial and AMR numbers.
b) Scan QR Code to submit photos and details.

Fit tamper-evident security seal/s.

 Turn on mains supply then valve **slowly** to bleed air / avoid over-speed damage to meter.
Conduct **leak check** and **check operation**.

CONSUMER WARRANTY

For products purchased after 1st January 2012

DEAR PLUMBER: PLEASE LEAVE FOR THE OWNER AFTER INSTALLATION

The following undertaking from Ozmeters Pty Ltd t/a Fair Water Meters (here in after FWM) shall apply to any purchaser of our product who is classified as a 'Consumer' under the Competition and Consumer Act (Cth) 2010, which includes prescribed requirements for warranties against defects, which are set out in Regulation 90 of the Competition and Consumer Regulations (Cth) 2010, (collectively, the Australian Consumer Law).

Contact Details

Fair Water Meters Tel: 1300 324 701
P.O. Box 100
Helensvale QLD 4212
info@fairwatermeters.com.au

Consumer Guarantees

FWM shall not be liable to the purchaser or user of any product, for any loss or damage (whether direct, indirect or consequential), cost or expenses, suffered or incurred by that purchaser, otherwise than as provided for in this document, the Australian Consumer Law and any other law that cannot be excluded.

Our goods come with guarantees that cannot be excluded under the Australian Consumer Law. You are entitled to a replacement or refund for a major failure and for compensation for any other reasonably foreseeable loss or damage. You are also entitled to have the goods repaired or replaced if the goods fail to be of acceptable quality and the failure does not amount to a major fault. Where a failure does not amount to a major failure, FWM is entitled to choose between providing you with a repair, replacement or refund. To obtain compensation, you would need to provide documentary evidence of the loss or damage suffered, and documentary evidence that such loss or damage was a reasonably foreseeable consequence of a failure by us to comply with a consumer guarantee under the Australian Consumer Law. Such evidence may include photographs, statutory declarations, receipts or reports (e.g. from your plumber), depending on the loss or damage.

Consumer Guarantees **do not apply** if you:

- Got what you asked for but simply changed your mind;
- Misused the product in any way that caused the problem; or
- Knew of or were made aware of the faults in the product before you bought it.

Supplier Warranty Terms

In addition to all rights and remedies to which you may be entitled under the Australian Competition and Consumer Act 2010 (Cth) and any other relevant legislation, the supplier warrants its products to be free from defect in materials or workmanship for a period of eight (8) years from date of purchase, or a period of fifty (50) years for brass components e.g. the manifold or base. Full details are listed on FWM's website under the Warranty section (www.fairwatermeters.com.au/warranty) The Supplier's Warranty only applies to the original owner and is not transferable.

FWM's liability under this supplier's warranty is subject to us being satisfied, in our reasonable opinion that a defect was caused by defective workmanship or materials and was not caused by or substantially contributed to by other factors or circumstances beyond our control. This extended warranty shall be void for the following reasons, including but not limited to:

- Usage** – the product was not used in normal circumstances;
- Application** – the product was not used for its manufactured application;
- Defective installation** – the product was not installed according to the appropriate Australian Standard or FWM's installation instructions by a licensed plumber;
- Maintenance and Repair** – the product was damaged during the process of maintenance and/or repair;
- Alteration and Modification** – the product was either altered or modified in a manner not recommended by the manufacturer;
- Neglect** – the product was not maintained as per the manufacturer's instructions;
- Misuse** – the product was not fitted inline;
- Cleaning** – the product was cleaned with an abrasive or corrosive cleaning agent;
- Water Properties** – the product incurred water damage due to below standard water properties;
- Water Supply** – the lines were not adequately flushed;
- Exposure** – the AMR module was submerged or the product was exposed to waterborne solids (e.g. thread tape, cuttings, grit etc), pressure exceeding 1,400 kPa, excessive temperature or unreasonable environmental factors.

The product part replacement Warranty **does not apply** to:

- Products or parts supplied with but not manufactured by Wasser-Geräte;
- Product finishes (lacquered, painted or similar finishes);
- Seals, washers, "O" rings, gaskets.

The product part replacement warranty is limited to replacement of parts of the invoice value that prove defective in material content and/or workmanship under normal installations. Cost for damages and/or labour charges incurred in installation, repair or replacement are excluded from this Warranty.

Reasonable Access

FWM will require adequate access to items to undertake warranty repairs. FWM will not be responsible for any damage and costs, or consequential damage or costs, where reasonable access is not available to the item and reserves the right to provide a replacement item only. If access to the building is not available when the service agent attends, the customer will be liable for the service call costs.

Warranty Claim

In order to claim under this Warranty for an uninstalled product you will need to contact FWM and provide proof of purchase (typically this will be a receipt). If the product has been installed and it is necessary to have it serviced under this Warranty, you are required to: Call the plumber that installed the product. (Most problems are caused by the supply lines not being cleaned out properly prior to connection.) If the plumber is satisfied that the problem could not be rectified, then contact FWM.

Fair Water Meters 1300 324 701 info@fairwatermeters.com.au

Any cost incurred by you in returning the product to FWM will be borne by you. FWM will then, at our option, either repair or replace the product, or refund your money and take back the product.

Where a product has been installed and a manufacturing fault is claimed, FWM will arrange for a Service Call to correct any fault on advice of the nature of the fault. If however on inspection, the fault is found to be:

- Caused by incorrect installation or other non-product cause, no responsibility for rectification will be undertaken by FWM, and a service call fee of \$150.00 will be charged; or
- The product is not manufactured by Wasser-Geräte, no responsibility for rectification will be undertaken by FWM and a service call fee of \$150.00 will be charged; and
- If any additional work is performed by FWM a service fee of \$150.00 per hour will be charged.

The benefits conferred by this Suppliers Warranty are in addition to all rights and remedies conveyed by the Competition and Consumer Act 2010 (Cth) and any other statutory rights to which you may already be entitled, and this warranty does not exclude, restrict or modify any such rights or remedies that are implied by law.

This warranty is provided by Ozmeters Pty Ltd t/a Fair Water Meters of PO Box 100, Helensvale, QLD 4212, Australia. Phone 1300 324 701.